

SIDE VIEW

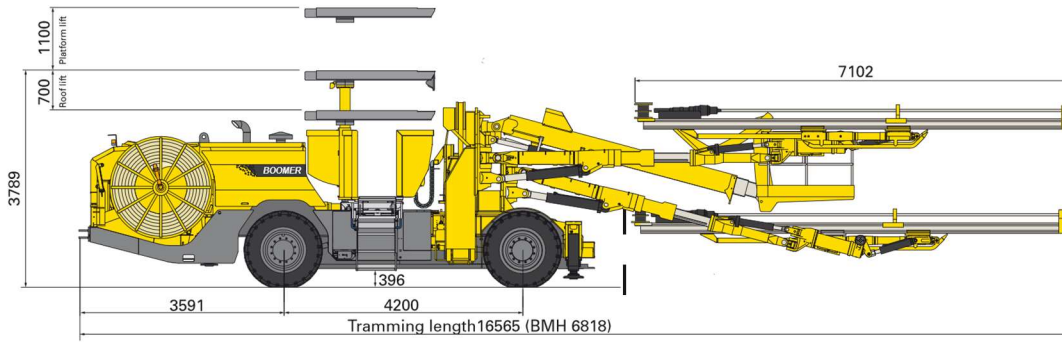

COVERAGE AREA

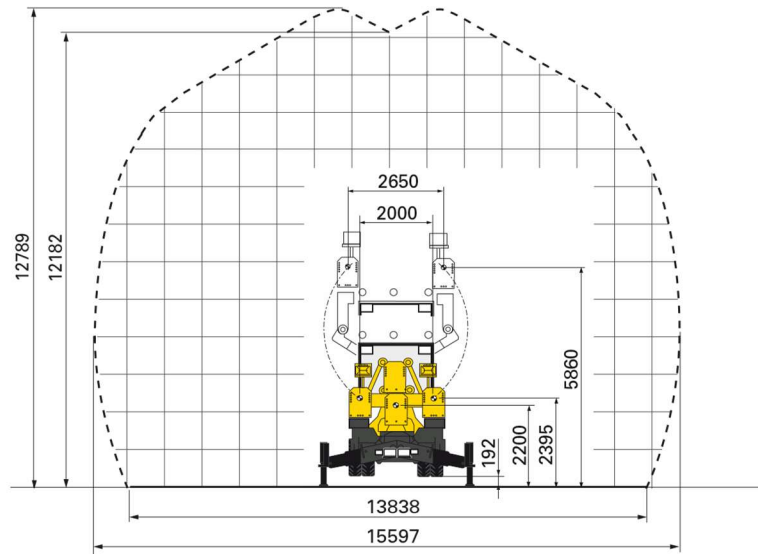

DIMENSIONS		
mm	Width	2 926
	Height roof down	3 089
	Height roof up	3 789
	Length with 18 ft feeds	16 565
	Ground clearance	396
	Turning radius	12 100/6 700

NOISE AND VIBRATION		
Operator sound pressure level in canopy, drilling, free field (ISO 11201)		104±6 dB(A) re 20µPa
Operator sound pressure level working close to machine, drilling, free field		104±6 dB(A) re 20µPa
Sound power level (ISO 3744), drilling, free field		130 dB(A) re 1pW
Vibration levels standing, canopy (ISO 2631-1)		0.1± 0.15 m/s ²

WEIGHT		
gross weight		
kg	Total	42 000
	Boom side	32 000
	Engine side	10 000

RECOMMENDED CABLE SIZE AND LENGTH				
Voltage	Type	Dimension, mm ²	Diameter, mm	Length, m
400 V	Buflex	4x185+3G35	55	100
440–500 V	Buflex	3x150+3G25	52	110
550 V	Buflex	3x120+3G25	46	135
690 V	Buflex	3x95+3G16	42	150
1 000 V	Buflex	3x50+3G10	32	250

TRAMMING SPEED		
km/h	On flat ground (rolling resistance 0.05)	>17
	On incline 1:8	> 6

G = Protection yellow/green
 Recommendations are given for surrounding temperature of 40°C.

